



TECHNICAL DATASHEET

TAB POLAR S92

ORDER INFORMATION

TAB ID
1000875

Short Code
S92

DIN Marking
59220 SMF

EAN Code
3838807027077

Quantity per EU/CNT pallet
36/72 pcs

TECHNOLOGY

Primary Function
Engine Start

Battery Technology
Flooded

Grid Type (pos/neg)
Expanded/Concasted

Grid Alloy (pos/neg)
Ca/Ca

Separator
PE

Electrolyte (g/cm³)
1,28

TECHNICAL INFORMATION

Voltage (V)
12

Capacity C20 (Ah)
92

CCA -18°C EN (A)
800

RC (min)
165

LxWxH (mm)
353x175x175

Total Weight (kg)
20.3

BOX DESIGN

Box Type
L5B

Cover Type
SMF

Colour
Black

Layout
0

BHD
B13

Terminal
1

DRAWING

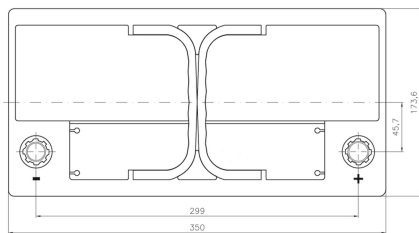
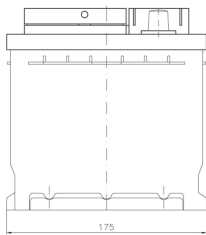
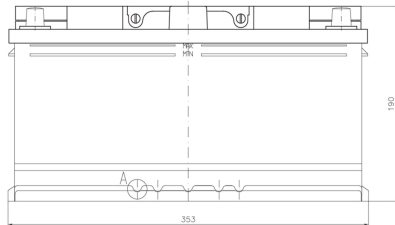

BHD

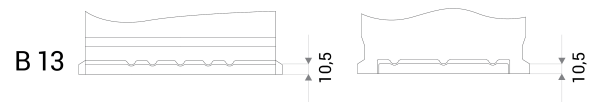

LAYOUT

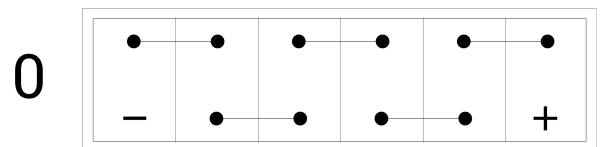

TERMINAL

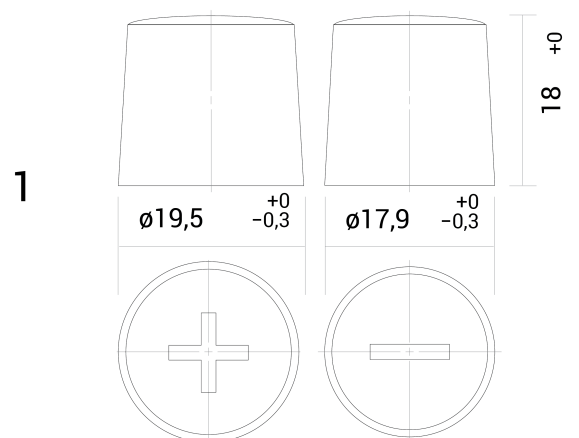

TECHNICAL DATASHEET

TAB POLAR S92

TAB d.d, Polena 6, SI-2392 Mežica, Slovenia, www.tab.si