

# TECHNICAL DATASHEET

## TOPLA HR - HOT REGION L2 AGM

### ORDER INFORMATION

TAB ID

Short Code  
**L2 AGM**

DIN Marking

EAN Code  
**3838807046764**

Quantity per EU/CNT pallet  
**0/110 pcs**

### TECHNOLOGY

Primary Function  
**Advanced Start/Stop Functionality**

Battery Technology  
**AGM - Absorbent Glass Mat**

Grid Type (pos/neg)  
**Casted/Concasted**

Grid Alloy (pos/neg)  
**Ca/Ca**

Separator  
**GM**

Electrolyte (g/cm<sup>3</sup>)  
**1,3**

### TECHNICAL INFORMATION

Voltage (V)  
**12**

Capacity C20 (Ah)  
**60**

CCA -18°C EN (A)  
**680**

RC (min)  
**109**

LxWxH (mm)  
**242x175x190**

Total Weight (kg)  
**17.9**

### BOX DESIGN

Box Type  
**L2**

Cover Type  
**Sealed**

Colour  
**Black**

Layout  
**0**

BHD  
**B13**

Terminal  
**1**

DRAWING

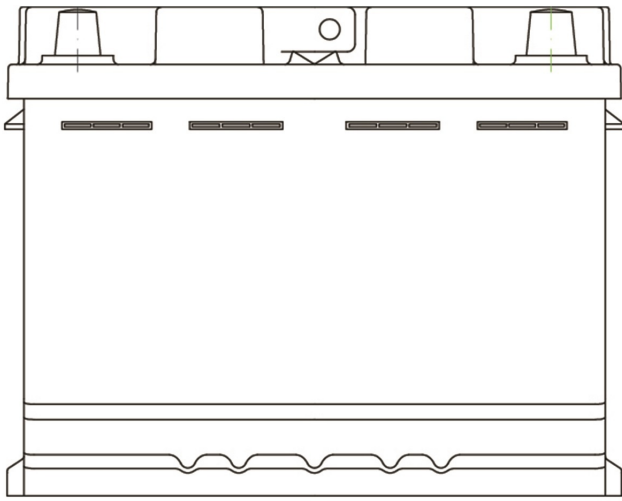

## BHD

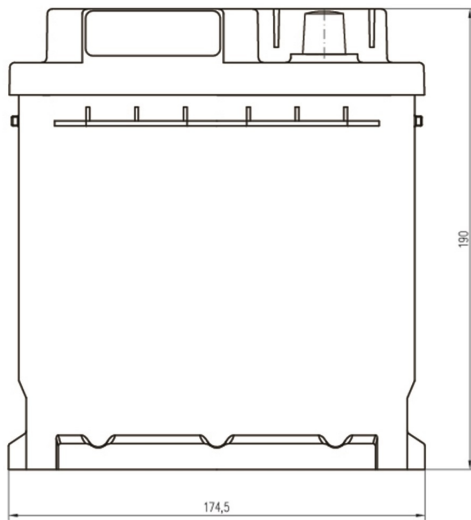
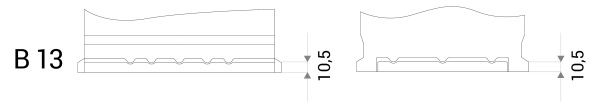

## LAYOUT

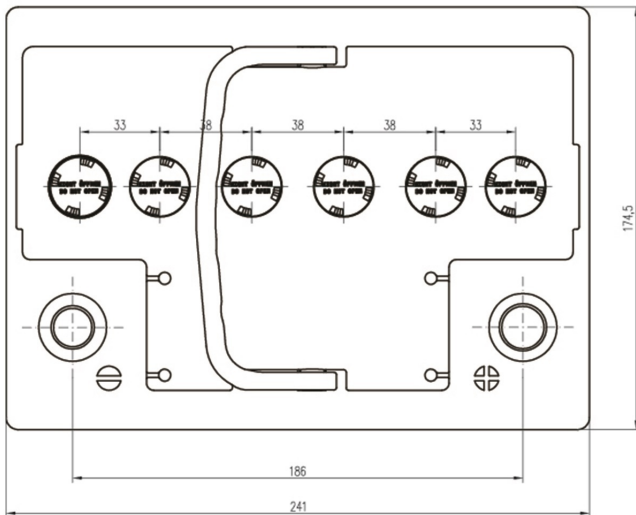
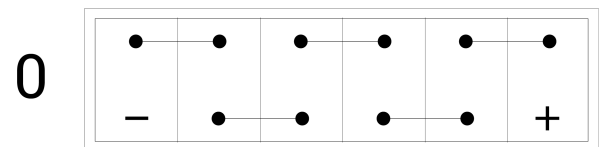

## TERMINAL

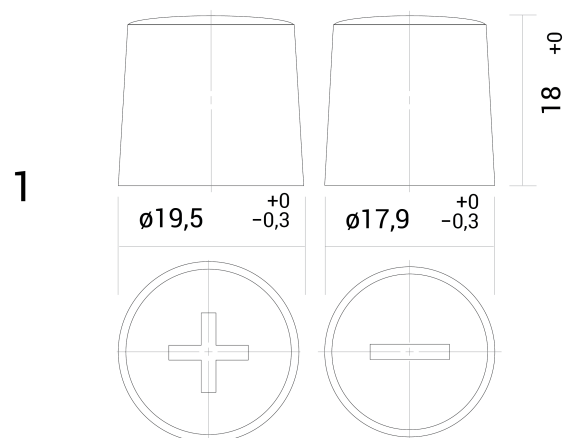

# TECHNICAL DATASHEET

## TOPLA HR - HOT REGION L2 AGM